



# HEAVY DUTY WIPER MOTOR

Model No. TMC-00901 / TMC-00902

## PRODUCT FEATURE

HEAVY DUTY WIPER MOTOR, 2-SPEEDS, SELF-PARKING FEATURE.  
INTERCHANGEABLE SWEEPING DEGREES: A°-B°-C°-D° DEGREES.

- DC-12V / 24V AVAILABLE.
- STALL TORQUE: 100 KG-CM.
- SWEEP ANGLE: A°-B°-C°-D° DEGREES INTERCHANGEABLE.
- SELF-PARKING & 2 SPEEDS.

Degree	A°	B°	C°	D°
I	60	70	80	90
II	40	45	50	55
III	83	100	110	120

## HOW TO CHANGE THE SWEEPING ANGLE?

- a. REMOVE THE WIPER ARM.
- b. REMOVE THE GEARBOX COVER.
- c. REMOVE THE CLIP (1) ON THE CONNECTION LINK (4).
- d. REMOVE THE LINK AND THE GEAR (5).
- e. LOOSEN THE FIXED SCREWS (3).
- f. TURN THE SWEEPING ANGLE PLATE (6) AND SET THE DESIRED DEGREE HOLE TO BE ALIGNED WITH THE GEAR CHANNEL "R" (5).
- g. TIGHTEN THE FIXED SCREWS (3) BACK.
- h. PLACE THE TRANSMISSION PIN (7) IN DESIRED HOLE ON GEAR.
- i. PLACE THE CLIP (1) BACK TO SECURE THE LINK OF GEAR (5) & WIPER SHAFT (2).
- j. LUBRICATE THE GEAR WITH SOME GREASE BEFORE PUTTING GEARBOX COVER BACK IN POSITION.
- k. RUN THE MOTOR TO THE PARK POSITION AND INSTALL THE WIPER ARM BACK.

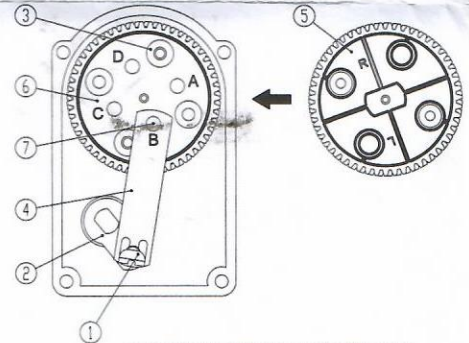

INSTALLATION DIAGRAM

## INSTALLATION

- LOCATE MOUNTING POSITION OF WIPER.
- DETERMINE SUITABLE SWEEPING DEGREES AND WHETHER ADEQUATE SPACE IS AVAILABLE.
- CHECK IF THE BLADE WILL WIPE THE DESIRED AREA OF WINDSHIELD. REFER TO SWEEPING DIAGRAM.
- RUN THE MOTOR TO THE PARK POSITION.
- NORMAL SWEEP POSITION ILLUSTRATED AS UNDER.
- IF ANY CHANGE ON SWEEP POSITION IS NEEDED, PLEASE MAKE THE APPROPRIATE ADJUSTMENT ON THE CONNECTOR FIRST.
- AS ABOVE IF SWEEP POSITION CHANGED PLEASE RESERVE ENOUGH SPACE TO AVOID COLLISION BETWEEN BLADE AND MOUNTING PLATE.
- CAUTION: SWEEP POSITION OF ARM SHALL NOT EXCEED MOUNTING AREA. OTHERWISE THE WIPER MOTOR WILL BE IMMEDIATELY OVER LOADED TO MAKE GEAR WHEEL STRIP FROM SHAFT WORM WHEEL.

## DIMENSIONS & WIRING DIAGRAM:

